

LTECH

DMX512 DECODER

LT-916-OLED

16
CHANNELS

OLED display
8 bit / 16 bit
3 kinds of DMX interfaces
Dimming Curve: 0.1-9.9

C **UL** US
E500585



Photoelectric
isolation

Short circuit / Over current / Overheat protection

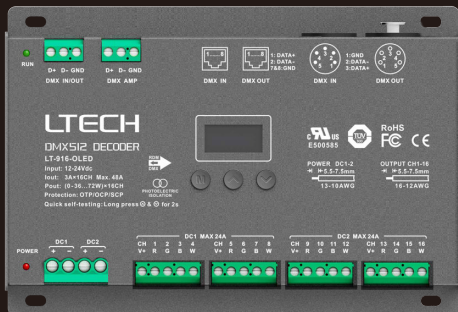

www.ltech-led.com

Product introduction

1. Designed for Hi-power multiple channels application, 16 channels output, and Max. 3A current per channel, up to 1152W output power.
2. Easy operation with OLED screen and touch buttons.
3. 4 kinds of modes available: DIM, CT, RGB, RGBW.
4. 5-pin XLR, RJ45 and green terminal DMX interface with photoelectric isolation, improve signal transmission efficiency and anti-interference ability, the green terminal also has signal amplifier function.
5. With RDM remote management protocol, the operations can be completed via the RDM master console, such as parameters browsing & settings, DMX address settings, equipment recognition, etc.
6. With firmware upgrade function.
7. With short circuit, over current and overheat protection, as well as warning function when a fault occurs.
8. With power-on state management and fast self-testing function.
9. 16bit (65536 levels) / 8bit (256 levels) grey level available.
10. Available for standard, linear, LOG or custom 0.1-9.9 dimming curve.

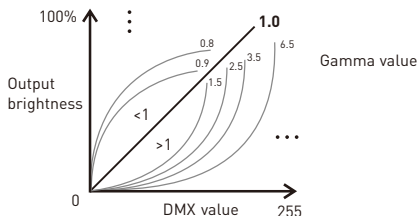

5-pin XLR



RJ45



RDM

Photoelectric
isolationShort circuit
protectionOverheat
protectionOver current
protection

Display

Technical specs

Model :	LT-916-OLED
Input signal :	DMX512/RDM
Input voltage :	12~24Vdc
Current load :	3A × 16CH Max. 48A
Output power :	(0~36W...72W) × 16CH Max. 1152W
DMX interfaces :	5-pin XLR, RJ45, green terminal
Control modes :	DIM/CT/RGB/RGBW
Dimming curves :	0.1~9.9, standard, linear, LOG
Grey level :	8bit (256 levels) / 16bit (65536 levels)
Photoelectric isolation :	Yes
Protection :	Short circuit / Overheat / Over current protection, recover automatically.
Working temperature :	-30°C~65°C
Dimensions :	180×122×39mm(L×W×H)
Package size :	193×127×41mm(L×W×H)
Weight (G.W.) :	730g



Product size

Unit: mm

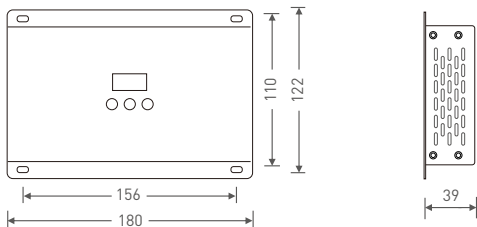

Main component description

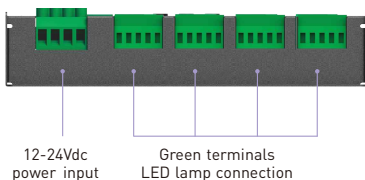
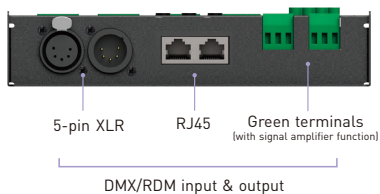
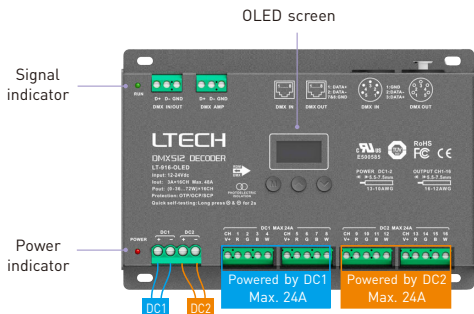

OLED screen interface



Press "M" key, switch entries.
 Long press "M" key, back to main page.
 Press "^" or "v" key, parameter adjustment.
 Exit: back to previous page.

1. DMX address settings

DMX: 001 Hz: High
 Mode: RGBW 8bit
 Curve: Standard
 Dim: Smo TOOL&v

Press "^" or "v" key to set DMX address.
 Range: 001-512

Main page

2. PWM frequency

DMX: 001 Hz: High
 Mode: RGBW 8bit
 Curve: Standard
 Dim: Smo TOOL&v

Press "^" or "v" key to choose. **No flicker in video camera.**
 Available : Std (standard)
 High
 Mid (middle)
 Low

Smooth and exquisite, human eye is comfortable. * It is recommended to use standard.

3. Modes

DMX: 001 Hz: High
 Mode: RGBW 8bit
 Curve: Standard
 Dim: Smo TOOL&v

Press "^" or "v" key to choose.
 Available : DIM/CT/CT2/RGB/RGBW

4. Grey scale

DMX: 001 Hz: High
 Mode: RGBW 8bit
 Curve: Standard
 Dim: Smo TOOL&v

Press "^" or "v" key to choose.
 Available : 8bit
 16bit (choose it if the master controller supports this function)

5. Dimming curves

DMX: 001 Hz: High
 Mode: RGBW 8bit
 Curve: Standard
 Dim: Smo TOOL&v

Press "^" or "v" key to choose.
 Available : **Standard**
 Linear
 LOG
 0.1-9.9
 It is recommended to use standard,
 0.1-9.9 is for special requirements.

6. Enhance dimming

```
DMX: 001 Hz: High
Mode: RGBW 8bit
Curve: Standard
Dim: Smo TOOL&v
```

Press “^” or “v” key to choose.

Available : **Std (standard)**

Smo (smooth)

* It is recommended to use standard.

Smo: This option with smooth processing, realizes flicker-free dimming and smooth dynamic effects.

7. Tool

```
DMX: 001 Hz: High
Mode: RGBW 8bit
Curve: Standard
Dim: Smo TOOL&v
```

Press “^” or “v”
key to enter submenu

```
Screen: ON+Addr
Contrast: 40%
Beep: ON TEST&v
EXIT&v
```

Press “^” or “v”
key to enter
submenu of test.

001

Screen: ON+Addr

Screensaver open and display address without operating in two minutes.

Screen: ON+black

Screensaver open and black without operating in two minutes.

```
DMX: 001 Hz: High
Mode: RGB 8bit
Curve: Standard
Dim: Smo TOOL&v
```

Screen: OFF

Screensaver not enable.

```
CH01: 255
CH02: 255
CH03: 255 [^&V]
CH04: 255 EXIT &V
```

Brightness setting
(range: 0-255)
Press “^” or “v”
to next page
Press “v” to exit

```
ALL: 255
[^&V]
EXIT &V
```

Change all value
simultaneously
(on the last page)

* Fast self-testing function: press “^” or “v” keys simultaneously for 2-3 seconds under any page, decoder will enter self-testing function.

Wiring diagram

1. Connecting LED lights:

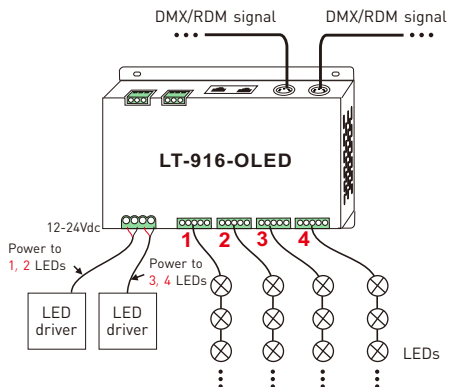
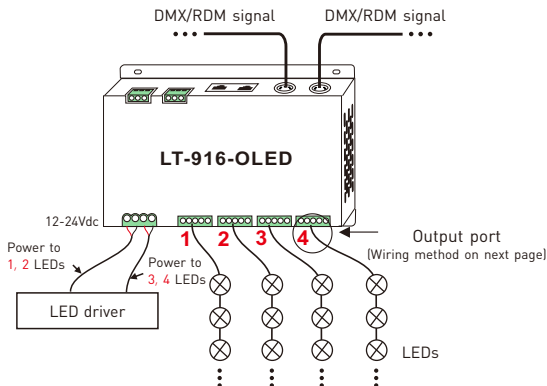

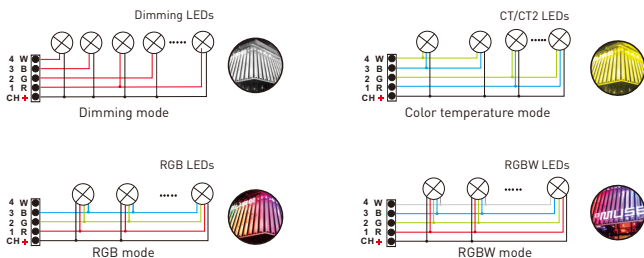

2. DMX console connection:

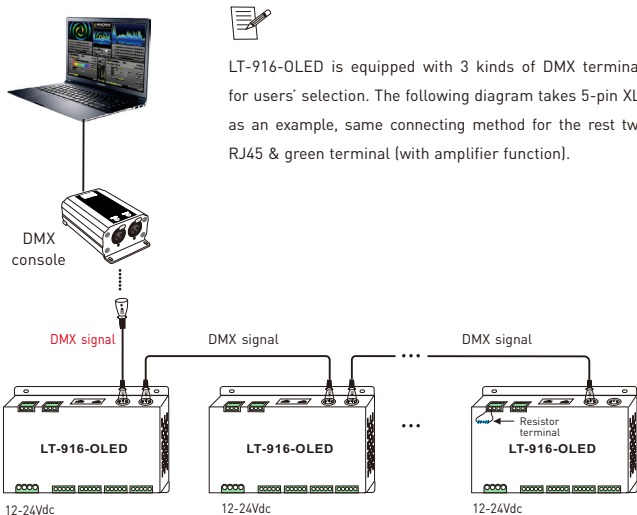

- * If the recoil effect occurs because of longer signal line or bad line quality, please try to connect 0.25W 90-120Ω terminal resistor at the end of each line.

3. The connection diagram of 3 kinds of DMX/RDM terminals:

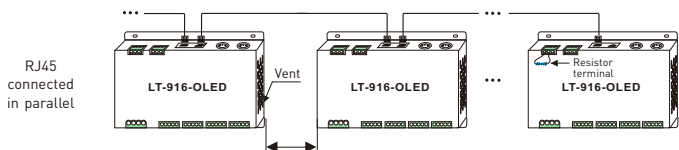
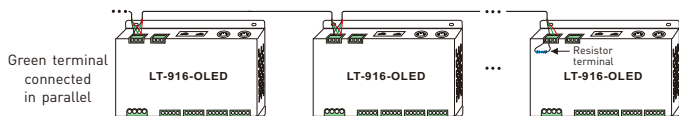
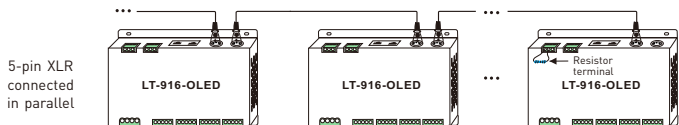

Installation distance > 20mm

These 3 terminals can be connected in a mixed way.

- * **Installation attentions:** Please reserve enough ventilation distance between decoders (>20mm), be sure not to block the vent, or it will affect lifetime of decoder for poor heat dissipation.

4. The connection diagram of AMP signal amplifier terminal:

- * Connecting with green terminal or an extra amplifier will be needed when more than 32 decoders are connected or use overlong signal wire (as shown below). Signal amplifier should not be more than 5 times continuously.

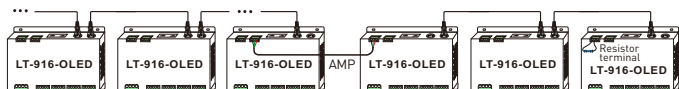

Address setting table

Mode	DIM	CT/CT2	RGB	RGBW	Mode	DIM	CT/CT2	RGB	RGBW			
Address quantity	4	8	12	16	Address quantity	8	16	24	32			
Resolution	8bit	8bit	8bit	8bit	Resolution	16bit	16bit	16bit	16bit			
Channel	1	001	001	001	001	Channel	1	001 002	001 002	001 002	001 002	
	2	001	002	002	002		2	001 002	003 004	003 004	003 004	003 004
	3	001	001	003	003		3	001 002	001 002	005 006	005 006	005 006
	4	001	002	003	004		4	001 002	003 004	005 006	005 006	007 008
	5	002	003	004	005		5	003 004	005 006	007 008	007 008	009 010
	6	002	004	005	006		6	003 004	007 008	009 010	009 010	011 012
	7	002	003	006	007		7	003 004	005 006	011 012	011 012	013 014
	8	002	004	006	008		8	003 004	007 008	011 012	011 012	015 016
	9	003	005	007	009		9	005 006	009 010	013 014	013 014	017 018
	10	003	006	008	010		10	005 006	011 012	015 016	015 016	019 020
	11	003	005	009	011		11	005 006	009 010	017 018	017 018	021 022
	12	003	006	009	012		12	005 006	011 012	017 018	017 018	023 024
	13	004	007	010	013		13	007 008	013 014	019 020	019 020	025 026
	14	004	008	011	014		14	007 008	015 016	021 022	021 022	027 028
	15	004	007	012	015		15	007 008	013 014	023 024	023 024	029 030
	16	004	008	012	016		16	007 008	015 016	023 024	023 024	031 032

* When you select CT2, the DMX address represents brightness, color temperature and constant power output respectively.

Work with RDM editor

LT-916-OLED can work with LTECH RDM editor (Model: WiFi-RDM01) to realize changing the parameters by long-range setting, wiring diagram as below:

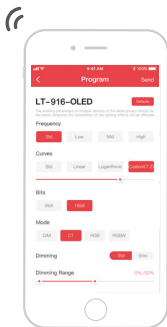
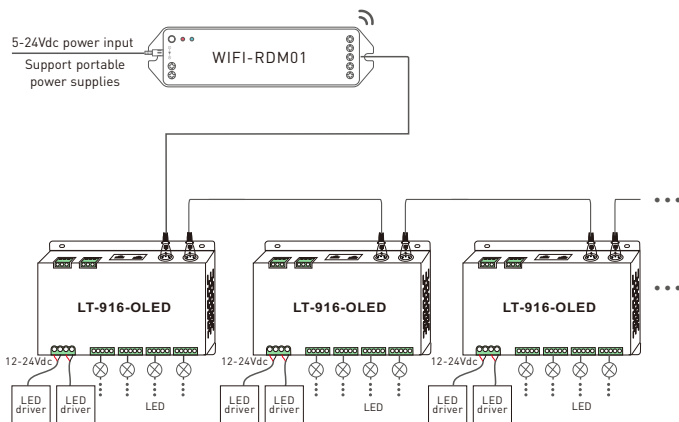

RDM editor App interface instruction

Download the App, setting the LT-916-OLED parameters (frequency, bit, curve, modes, dimming range, screensaver, etc.) after well connecting the RDM editor, more details, please check the manual of WiFi-RDM01.

Well installation of products first, then working with WiFi -RDM01 to realize setting parameters and firmware upgrade by App.

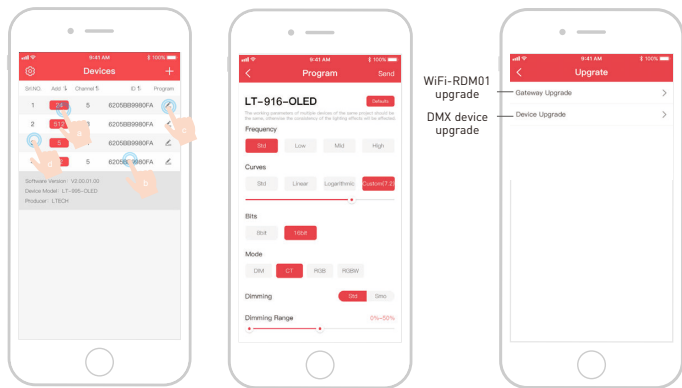

- a: Click "Add", edit the address in corresponding box.
- b: Click "ID", get more product details.
- c: Click " ", enter edited interface.
- d: Click "No.", issue the recognizing command.

WiFi-RDM01
upgrade
DMX device
upgrade

Supporting WiFi-RDM01 upgrade
and DMX driver upgrade.

* This manual is subject to changes without further notice.
Product functions depend on the goods.
Please feel free to contact our official distributors if you have any question.

LTECH 雷特

DMX512 DECODER

LT-916-OLED

16
CHANNELS

OLED显示屏
8 bit / 16 bit
3种DMX接口
调光曲线: 0.1-9.9
短路、过流、过温保护

C  US
E500585

RDM
DMX

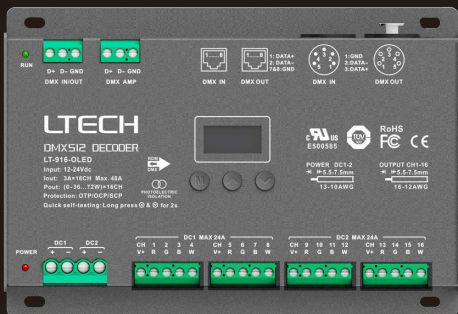

光电隔离



www.ltech.cn

产品介绍

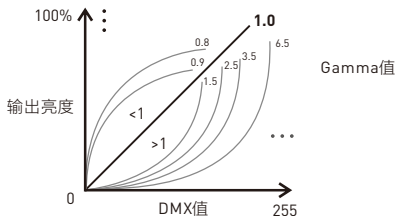
- 1、本产品为大功率多通道应用而设计，共有16个通道输出，每通道最大3A电流，总功率可高达1152W；
- 2、使用OLED屏和轻触按键组成人机界面，显示内容丰富，操作简单快捷；
- 3、具有调光、色温、RGB、RGBW 4种模式选择；
- 4、提供5针XLR、绿色端子、RJ45三种具有信号隔离功能的DMX接口，提高信号传输效率和抗干扰能力，其中绿色端子还有信号放大功能。
- 5、具有RDM远程管理协议，通过RDM主控可对其进行参数浏览与设置、DMX地址修改、设备识别等操作；
- 6、具有固件升级功能；
- 7、具有短路、过流、过温保护与自动恢复功能，并有故障警示提示功能；
- 8、具有上电状态管理及快速自测功能。
- 9、16bit(65536级)/8bit(256级)灰度级可选。
- 10、标准、线性、对数及自定义0.1~9.9等调光曲线可选。



5针 XLR



RJ45



RDM



光电隔离



短路保护



过温保护



过流保护



显示

性能参数

产品型号：	LT-916-OLED
输入信号：	DMX512/RDM
输入电压：	12- 24Vdc
负载电流：	3A×16路 Max. 48A
输出功率：	[0~36W...72W]×16路 Max. 1152W
DMX接口：	5针XLR, RJ45, 绿色端子
控制模式：	调光/色温/RGB/RGBW
调光曲线：	0.1~9.9, 标准, 线性, 对数
灰度等级：	8bit(256级)/16bit(65536级)可选
光电隔离：	有
保护：	短路、过流、过温保护, 可自动恢复
工作温度：	-30°C~65°C
产品尺寸：	L180×W122×H39mm
包装尺寸：	L193×W127×H41mm
重量(毛重):	730g



产品尺寸

单位：mm

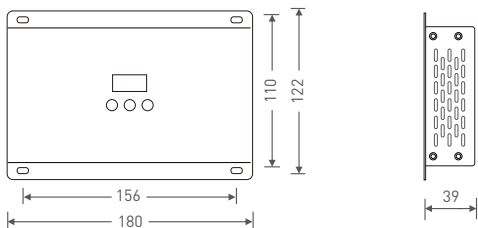

部件图

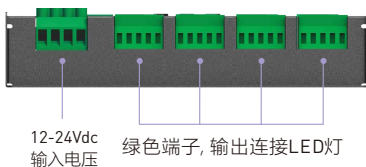
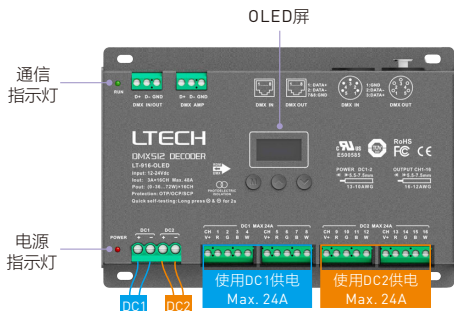

OLED屏界面图



按M键，切换条目

长按M键，返回至主显示界面

按^或v键，调整参数

EXIT: 返回至上一级菜单

1、DMX地址设置

DMX: **001** Hz: High
Mode: RGBW 8bit
Curve: Standard
Dim: Smo TOOL&v

主显示界面

按^或v键，进行DMX地址设置

范围：1~512

2、PWM频率

DMX: 001 Hz: **High**
Mode: RGBW 8bit
Curve: Standard
Dim: Smo TOOL&v

按^或v键进行选择

可选项：



3、模式

DMX: 001 Hz: High
Mode: **RGBW** 8bit
Curve: Standard
Dim: Smo TOOL&v

按^或v键进行选择

可选项：DIM(调光)、CT/CT2(色温)、RGB、RGBW

4、灰度等级

DMX: 001 Hz: High
Mode: RGBW **8bit**
Curve: Standard
Dim: Smo TOOL&v

按^或v键进行选择

可选项：8bit

16bit (主控支持此功能时，可使用)

5、调光曲线

DMX: 001 Hz: High
Mode: RGBW 8bit
Curve: **Standard**
Dim: Smo TOOL&v

按^或v键进行选择

可选项：Standard(标准)

Linear(线性)

Log(对数)

0.1~9.9

* 推荐使用standard,

有特殊要求时可使用0.1-9.9

连接示意图

1. 连接LED灯

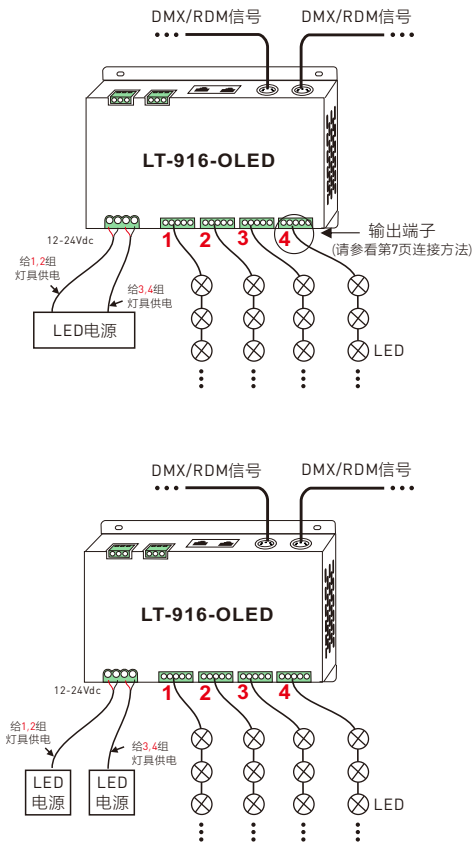

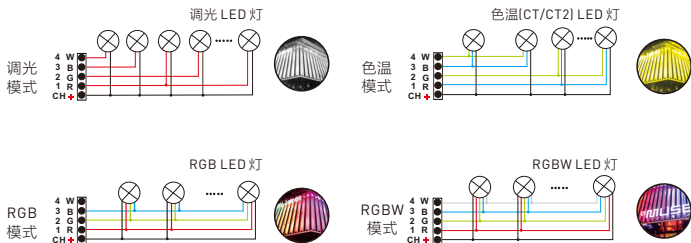

2. DMX系统连接

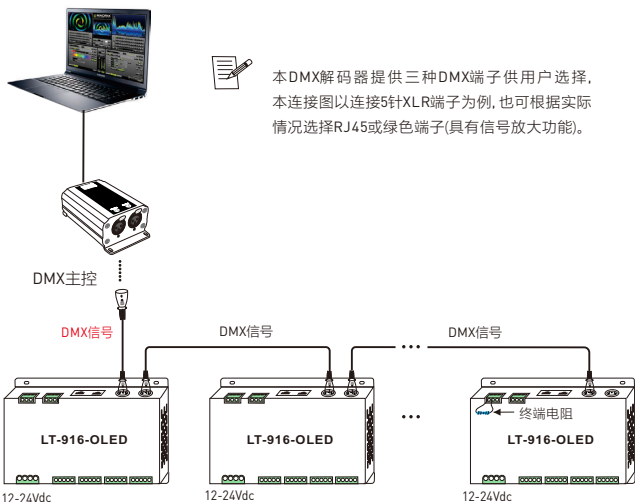

本DMX解码器提供三种DMX端子供用户选择, 本连接图以连接5针XLR端子为例, 也可根据实际情况选择RJ45或绿色端子(具有信号放大功能)。

* 当信号线较长或者线材质量等原因造成信号反冲效应影响使用, 可以尝试在每路信号线末端连接0.25W 90-120Ω终端电阻解决。

3 三种DMX端口的连接示意图

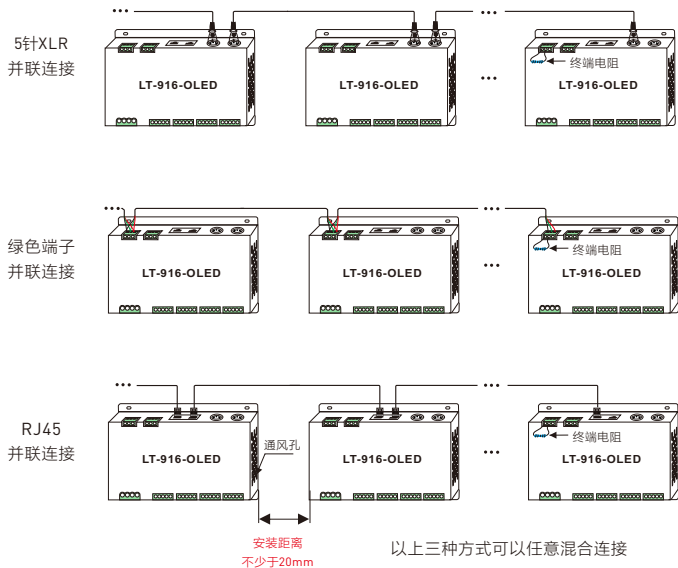

* 安装注意事项：请在解码器与解码器之间预留通风距离（最少20mm），切勿堵塞通风孔，否则会因设备散热不畅影响使用寿命。

4 AMP信号放大端子连接图

* 当DMX解码器过多（超过32台），或信号线过长，需加信号放大器或使用绿色端子接口进行信号放大（见下图），信号放大不能连续超过5次。

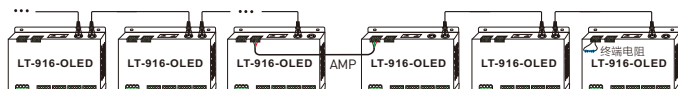

模式地址设置表

模式	DIM	CT/CT2	RGB	RGBW	
地址数量	4	8	12	16	
分辨率	8bit	8bit	8bit	8bit	
通道数	1	001	001	001	001
	2	001	002	002	002
	3	001	001	003	003
	4	001	002	003	004
	5	002	003	004	005
	6	002	004	005	006
	7	002	003	006	007
	8	002	004	006	008
	9	003	005	007	009
	10	003	006	008	010
	11	003	005	009	011
	12	003	006	009	012
	13	004	007	010	013
	14	004	008	011	014
	15	004	007	012	015
	16	004	008	012	016

模式	DIM	CT/CT2	RGB	RGBW	
地址数量	8	16	24	32	
分辨率	16bit	16bit	16bit	16bit	
通道数	1	001 002	001 002	001 002	001 002
	2	001 002	003 004	003 004	003 004
	3	001 002	001 002	005 006	005 006
	4	001 002	003 004	005 006	007 008
	5	003 004	005 006	007 008	009 010
	6	003 004	007 008	009 010	011 012
	7	003 004	005 006	011 012	013 014
	8	003 004	007 008	011 012	015 016
	9	005 006	009 010	013 014	017 018
	10	005 006	011 012	015 016	019 020
	11	005 006	009 010	017 018	021 022
	12	005 006	011 012	017 018	023 024
	13	007 008	013 014	019 020	025 026
	14	007 008	015 016	021 022	027 028
	15	007 008	013 014	023 024	029 030
	16	007 008	015 016	023 024	031 032

* 当选择模式为CT2时，DMX地址分别表示亮度及色温，恒功率输出。

与RDM编辑器配合使用

LT-916-OLED可以与我司RDM编辑器（型号WiFi-RDM01）配合使用，以实现手机远程浏览与设置参数、固件升级等，连接图如下：

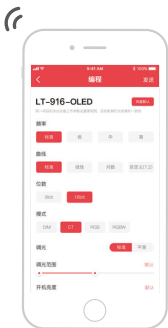
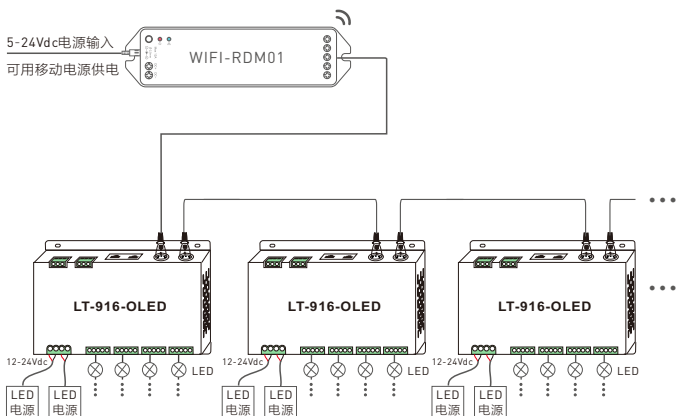

RDM编程器APP界面介绍

手机下载APP，与RDM编辑器连接成功后，即可通过APP设置LT-916-OLED所有参数如频率、位数、曲线、模式、调光范围、屏保等参数，具体请参看WiFi-RDM01的使用说明书。

配套使用WiFi-RDM01后，即可实现先安装再用APP设置参数及进行固件升级，随心所欲，免高空作业。

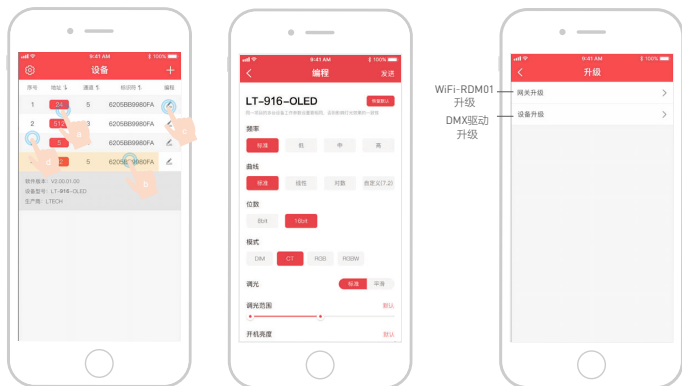

- a: 点击“地址”对应方框可编辑地址；
 b: 点击“标识符”出现产品详细信息；
 c: 点击编程按钮“编程”则进入编辑界面；
 d: 点击序号发出识别命令。

在APP进行固件升级

* 本说明书的内容如有变更，恕不另行通知。
 若内容与您使用的功能有所不同，则以实物为准。
 如有疑问，欢迎向我司授权的经销商咨询。